



HOW TO MAKE A HOME RUN.™

# Use And Care

## G U I D E

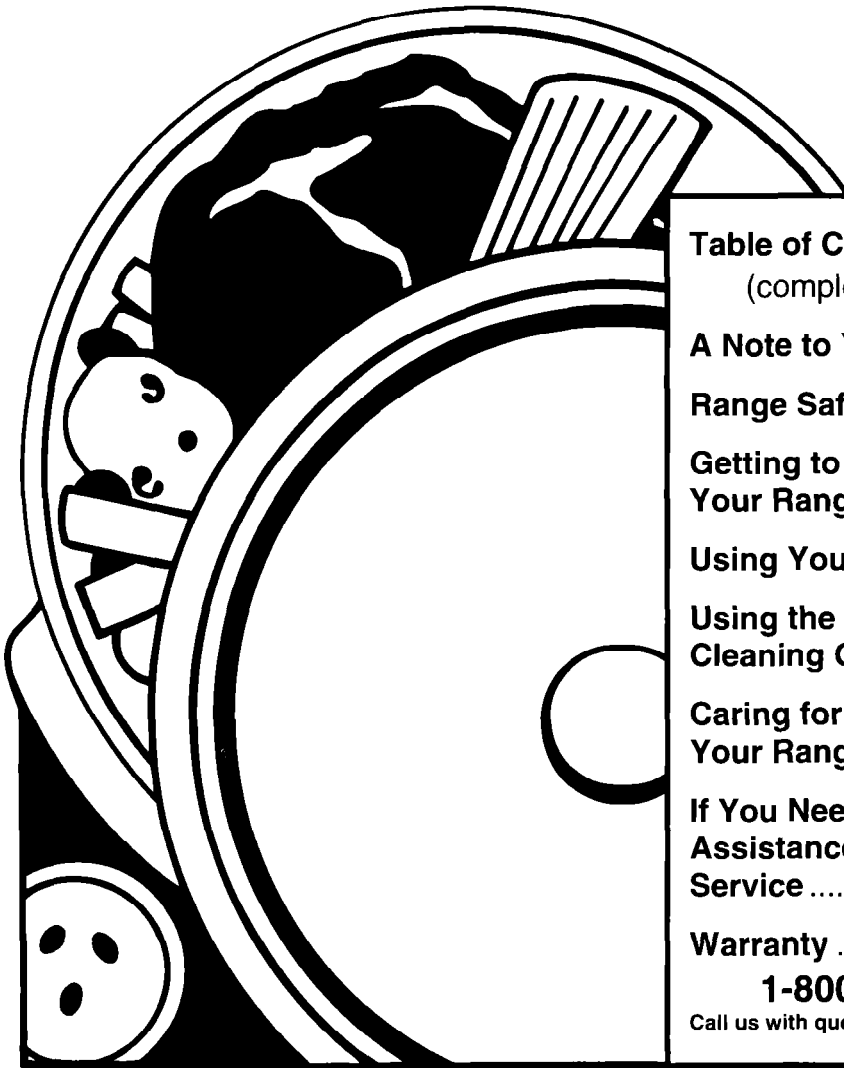

Table of Contents (complete) .....	2
A Note to You .....	3
Range Safety .....	4
Getting to Know Your Range .....	8
Using Your Range .....	9
Using the Self- Cleaning Cycle .....	22
Caring for Your Range .....	25
If You Need Assistance or Service .....	31
Warranty .....	36
<b>1-800-253-1301</b>	
Call us with questions or comments.	

### SELF-CLEANING GAS RANGE

5/95

TO THE INSTALLER: PLEASE LEAVE THIS INSTRUCTION BOOK WITH THE UNIT.

TO THE CONSUMER: PLEASE READ AND KEEP THIS BOOK FOR FUTURE REFERENCE.

MODEL SF378PEW

# Table of Contents

<b>A Note to You</b> .....	3	The oven vent .....	20
<b>Range Safety</b> .....	4	The storage drawer .....	20
<b>Getting to Know Your Range</b> .....	8	The anti-tip brackets .....	21
<b>Using Your Range</b> .....	9	<b>Using the Self-Cleaning Cycle</b> .....	22
Using the surface burners .....	9	How the cycle works .....	22
Positioning racks and pans .....	11	Before you start .....	22
For best air circulation .....	12	Setting the controls .....	23
Setting the clock .....	13	Special tips .....	24
Using the Minute Timer .....	13	<b>Caring for Your Range</b> .....	25
Baking/roasting .....	14	Surface burner grates .....	25
Adjusting the oven temperature control .....	15	Surface burners and cooktop .....	26
Broiling .....	15	Cleaning chart .....	28
Broiling tips .....	16	The oven light .....	30
Energy saving tips .....	17	<b>If You Need Assistance or Service</b> .....	31
Using the automatic MEALTIMER™ clock .....	18	<b>Warranty</b> .....	36

# A Note to You

## Thank you for buying a Whirlpool® appliance.

Because your life is getting busier and more complicated, Whirlpool ranges are easy to use, save time, and help you manage your home better. To ensure that you enjoy years of trouble-free operation, we developed this Use and Care Guide. It is full of valuable information about how to operate and maintain your appliance properly and safely. Please read it carefully.

Also, please complete and mail in the Ownership Registration Card provided with your appliance. The card helps us notify you about any new information on your appliance.

## Please record your model's information.

Whenever you call to request service for your appliance, you need to know your complete model number and serial number. You can find this information on the model and serial number plate (see diagram on page 8 for location of plate).

Please also record the purchase date of your appliance and your dealer's name, address, and telephone number.

Model Number \_\_\_\_\_

Serial Number \_\_\_\_\_

Purchase Date \_\_\_\_\_

Dealer Name \_\_\_\_\_

Dealer Address \_\_\_\_\_

Dealer Phone \_\_\_\_\_

**Keep this book and the sales slip together in a safe place for future reference.**

**Our Consumer Assistance Center  
number is toll-free 24 hours a day.**

**1-800-253-1301**

# Range Safety

## Your safety is important to us.

This guide contains safety statements under warning symbols. Please pay special attention to these symbols and follow any instructions given. Here is a brief explanation of the use of the symbol.

### **WARNING**

This symbol alerts you to such dangers as personal injury, burns, fire, and electrical shock.



### **WARNING**

- ALL RANGES CAN TIP.
- INJURY TO PERSONS COULD RESULT.
- INSTALL ANTI-TIP DEVICES PACKED WITH RANGE.
- SEE INSTALLATION INSTRUCTIONS.

**NOTE:** For more information, see the “The anti-tip brackets” on page 21.

## IMPORTANT SAFETY INSTRUCTIONS

### READ AND SAVE THESE INSTRUCTIONS

### **WARNING**

To reduce the risk of fire, electrical shock, injury to persons, or damage when using the range, follow basic precautions, including the following:

**WARNING:** If the information in this manual is not followed exactly, a fire or explosion could result causing property damage, personal injury, or death.

**Do not store or use gasoline or other flammable vapors and liquids in the vicinity of this or any other appliance.**

#### **WHAT TO DO IF YOU SMELL GAS:**

- Do not try to light any appliance.
- Do not touch any electrical switch; do not use any phone in your building.
- Immediately call your gas supplier from a neighbor’s phone. Follow the gas supplier’s instructions.
- If you cannot reach your gas supplier, call the fire department.

**Installation and service must be performed by a qualified installer, service agency, or the gas supplier.**

## General

- Install or locate the range only in accordance with the provided Installation Instructions. The range must be installed by a qualified installer. The range must be properly connected to the proper gas supply and checked for leaks. The range must also be properly connected to electrical supply and grounded.
- Gas fuels and their use in appliances can cause minor exposures to benzene, formaldehyde, carbon monoxide, and soot, primarily from incomplete combustion. Significant exposure to these substances could cause cancer or reproductive harm. Properly adjusted burners with a blue, rather than a yellow, flame will minimize incomplete combustion. Venting with a hood or an open window will further minimize exposure.
- Do not store things children might want above the range. Children could be burned or injured while climbing on it.
- Do not leave children alone or unattended in area where the range is in use. They should never be allowed to sit or stand on any part of the range. They could be burned or injured.
- Do not operate the range if it is damaged or not working properly.
- Do not use the range for warming or heating the room. Persons could be burned or injured, or a fire could start.
- Do not attempt to light the oven burner during a power failure. Personal injury could result. Reset oven controls to the off position in the event of a power failure.
- Use the range only for its intended use as described in this manual.



- Do not touch surface burners, areas near surface burners, or interior surfaces of oven. Areas near surface burners and

interior surfaces of an oven become hot enough to cause burns. During and after use, do not touch, or let clothing or other flammable materials contact surface burners, areas near surface burners, or interior surfaces of oven until they have had sufficient time to cool. Other surfaces of the range, such as the oven vent opening, the surface near the vent opening, the cooktop, and the oven door and window, could also become hot enough to cause burns.



- Do not wear loose or hanging garments when using the range. They could ignite if they touch an open flame and you could be burned.
- Use only dry pot holders. Moist or damp pot holders on hot surfaces could result in burns from steam. Do not let pot holder touch an open flame. Do not use a towel or bulky cloth for a pot holder. It could catch on fire.
- Keep range vents unobstructed.
- Do not heat unopened containers. They could explode. The hot contents could cause burns and container particles could cause injury.
- Do not store flammable materials on or near the range. The fumes could create an explosion and/or fire hazard.
- Do not use the oven for storage.
- Do not use aluminum foil to line areas around surface burners, oven bottom, or any other part of the range. Use aluminum foil only as recommended in this manual.
- Never use a match or other flame to look for a gas leak. Explosion and injury could result.
- Know where your main gas shutoff valve is located.

## When using the cooktop

- Make sure the utensils you use are large enough to contain food and avoid boil-overs and spillovers. Heavy splattering or spillovers left on a range could ignite and burn you. Pan size is especially important in deep fat frying.
- Check to be sure glass cooking utensils are safe for use on the range. Only certain types of glass, glass-ceramic, ceramic, earthenware, or other glazed utensils are suitable for cooktops without breaking due to the sudden change in temperature.
- Never leave surface burners unattended at high heat settings. A boilover could result and cause smoking and greasy spillovers that could ignite.



- Turn pan handles inward, but not over other surface burners. This will help reduce the chance of burns, igniting of flammable materials, and spills due to bumping of the pan.
- Do not use decorative covers or trivets over the surface burners.

## When using the oven

- Always position the oven rack(s) in desired location while oven is cool.
- Use care when opening oven door. Let hot air or steam escape before removing or replacing food.

## Grease

- Grease is flammable. Do not allow grease to collect around cooktop or in vents. Wipe spillovers immediately.



- Do not use water on grease fires. Never pick up a flaming pan. Smother flaming pan by covering with a well-fitted lid, cookie sheet, or flat tray. Flaming grease outside of pan can be extinguished with baking soda or, if available, a multipurpose dry chemical or foam-type extinguisher.

## Care and cleaning

- Small amounts of formaldehyde and carbon monoxide are given off in the Self-Cleaning cycle from fiberglass insulation and food decomposition. Significant exposure to these substances could cause cancer or reproductive harm. Exposure can be minimized by venting with a hood or open window and wiping out excess food spills prior to self-cleaning.



- Do not use oven cleaners. No commercial oven cleaner or oven liner protective coating of any kind should be used in or around any part of the oven.
- Before self-cleaning the oven, remove broiler pan, broiler grid, oven racks, and other utensils. Do not use your oven to clean miscellaneous parts unless you are instructed to do so in this Use and Care Guide.

- Do not clean door heat seal. It is essential for a good seal. Care should be taken not to rub, damage, or move the seal. Clean only parts recommended in this Use and Care Guide.
- Do not repair or replace any part of the range unless specifically recommended in this manual. All other servicing should be referred to a qualified technician.
- Any additions, changes, or conversions required in order for this appliance to satisfactorily meet the application needs must be made by a Whirlpool service company or Qualified Agency.
- Disconnect the electrical supply and the gas supply at the shutoff valve near the range before servicing the range.

**- READ AND SAVE THESE INSTRUCTIONS -**

# Getting to Know Your Range

This section contains captioned illustrations of your range. Use them to become familiar with the location and appearance of all parts and features. To help you find information on specific parts and features quickly, page references are included.

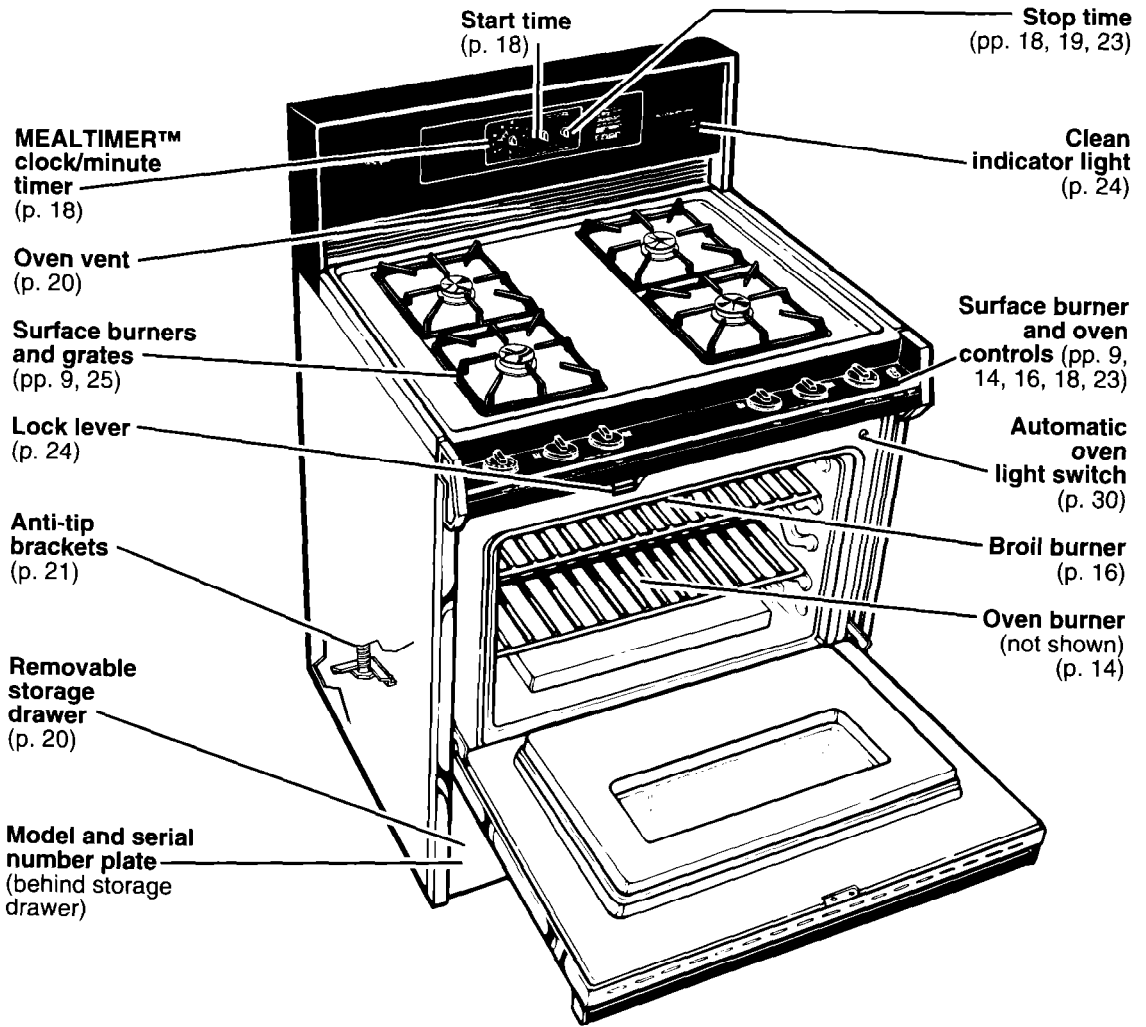

## Control panel

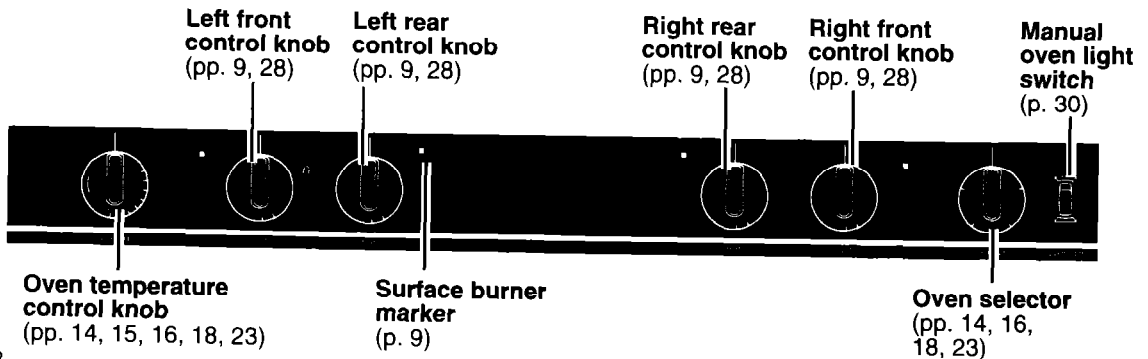

# Using Your Range

To obtain the best cooking results possible, you must operate your range properly. This section gives you important information for efficient and safe use of your range.

## Using the surface burners

Your range is equipped with electric ignitors. Electric ignitors automatically light the burners each time they are used.

**Push in control knob and turn counterclockwise** to the LITE position. The clicking sound is the ignitor sparking. **Visually check that burner has lit.**

**To stop the clicking sound after the burner lights, turn the control knob to the desired setting.** The control knob has stops for HI, medium, and low. However, you can set the control knob anywhere between HI and OFF.

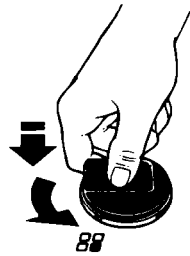

**Push in and turn counterclockwise**

## Surface burner markers

The solid dot in the surface burner marker shows which surface burner is turned on by that knob.

## Burner heat settings

**Use** correct burner heat settings (see next page). If the heat setting is too high, it can:

- **Char** bacon and cause curling.
- **Make** eggs tough and crisp at the edges.
- **Toughen** liver, fish, and seafood.
- **Scorch** delicate sauces and custards.
- **Cause** a boilover.

## USING YOUR RANGE

Until you get used to the settings, use the following as a guide. For best results, start cooking at the high setting; then turn the control knob down to continue cooking.

SETTING	RECOMMENDED USE
LITE	<ul style="list-style-type: none"><li>• To light the burner. After the burner lights, turn control back to a desired setting to stop the clicking of the ignitor.</li></ul>
HI	<ul style="list-style-type: none"><li>• To start foods cooking.</li><li>• To bring liquids to a boil.</li></ul>
medium	<ul style="list-style-type: none"><li>• To hold a rapid boil.</li><li>• To fry chicken or pancakes.</li><li>• For gravy, pudding, and icing.</li><li>• To cook large amounts of vegetables.</li></ul>
low	<ul style="list-style-type: none"><li>• To keep food warm until ready to serve.</li></ul>

**NOTE:** Do not cook with the control in the LITE position.

### In case of a prolonged power failure

Surface burners can be manually lighted. Hold a lit match near a burner and turn the control knob to the LITE position. After the burner lights, turn the control knob to the desired setting.

## ⚠ WARNING

### Explosion Hazard

- Burner flame should not extend beyond the edge of the cooking utensil. The flame could burn you and cause poor cooking results.
- Be sure all control knobs are turned to OFF when you are not cooking. Someone could be burned or a fire could start if a burner is accidentally left ON.
- If the flame should go out while cooking, or if there is a strong gas odor, turn the burners OFF. Wait five minutes for the gas odor to disappear before relighting burner. If gas odor is still present, see safety note on page 4. Failure to follow these precautions could result in explosion or fire.

### Cookware tips

No one brand of cookware is best for all people. Knowing something about pan materials and construction will help you select the correct cookware for your needs.

- **NOTE: For best results and greater fuel efficiency,** use only flat-bottomed cookware in good condition.
- **The pan** should have straight sides and a tight-fitting lid.
- **Choose medium to heavy gauge** (thickness) pans that are fairly lightweight.
- **The pan material** (metal or glass) affects how fast heat transfers from the surface burners through the pan material and how evenly heat spreads over the pan bottom. Choose pans that provide the best cooking results.
- **Handles** should be made of a sturdy, heat-resistant material and be securely attached to the pan.

- **Pans** should be easy to clean. Check to be sure there are no crevices, rough edges, or areas where food might collect.
- **Be sure pans** do not tip, whether they are full or empty.
- **Use cookware** only as it was intended to be used. Follow pan instructions. This is very important for glass cookware because some should be used only in the oven. Other pans are marked as flameware and may be used on the surface burners.
- **Do not leave** an empty utensil, or one which has boiled dry, on a hot surface burner. The utensil could overheat and could damage the utensil or cooking product.

**Home canning information**

The larger diameter of most water-bath or pressure canners combined with high heat settings for long periods of time can cause damage to the cooktop.

**To protect your range:**

- **For best results**, use a canner which can be centered over the surface burner.
- **Do not place canner** on two surface burners at the same time. Too much heat will build up and will damage the cooktop.
- **Start with hot water.** This reduces the time the control is set on high. Reduce heat setting to lowest position needed to keep water boiling.
- **Refer** to your canner manual for specific instructions.

**Positioning racks and pans**

For baking/roasting with one rack, place the rack so the top of the food will be centered in the oven.

**Rack placement for specific foods:**

FOOD	RACK POSITION
Frozen pies, large roasts, turkeys, angel food cakes	1st or 2nd rack guide from bottom
Bundt cakes, most quick breads, yeast breads, casseroles, meats	2nd rack guide from bottom
Cookies, biscuits, muffins, cakes, nonfrozen pies	2nd or 3rd rack guide from bottom

When baking on two racks, arrange racks on first and third rack guides from bottom.

**NOTE:** For recommended rack placement when broiling, see “Broiling rack position chart” on page 17.

**⚠ WARNING**

**Personal Injury Hazard**

- Always position oven rack(s) in desired location before turning oven on. Be sure the rack(s) is level.
- If rack(s) must be moved while oven is hot, use pot holders or oven mitts to protect hands.
- Do not place items on the open oven door.
- Be careful when installing and removing large food items from extra oven rack position. Food will be closer to hot surfaces, including oven bottom and sides.

Failure to follow the above precautions could result in personal injury.

continued on next page

### Extra oven rack position (roasting rack)

When roasting food too large to be placed in oven with rack in lowest position, **place** rack on bottom of oven.

**For proper roasting, follow these guidelines:**

- **The rack** must be level.
- **Use** adequate amount of liquid (meat juices or water) so food does not get overdone.
- **Do not try to pull rack out over door.** Rack will be at the same level as door when door is opened.

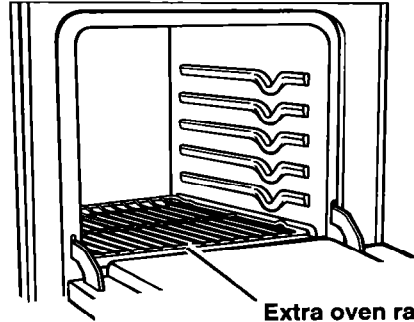

Extra oven rack position

---

### For best air circulation

Hot air must circulate around the pans in the oven for even heat to reach all parts of the oven. This results in better baking.

- **Place** the pans so that one is not directly over the other.
- **For best results, allow** 1½-2 inches (4-5 cm) of space around each pan and between pans and oven walls. There must be a minimum space of 1 inch (2.5 cm).
- **Use** only one cookie sheet in the oven at one time.

**Use the following as a guide to determine where to place the pans:**

#### One pan

Place in the center of the oven rack.

#### Two pans

Place in opposite corners of the oven rack.

#### Three or four pans

Place in opposite corners on each oven rack. Stagger pans so no pan is directly over another.

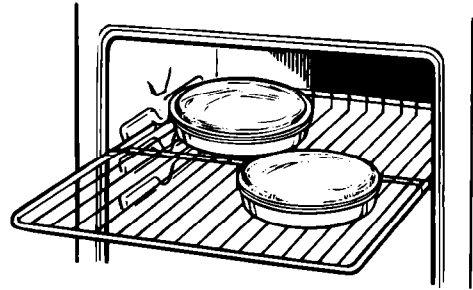

## Setting the clock

Push in and turn the Minute Timer Knob to set the clock.

1. Push in Minute Timer Knob and turn **clockwise** until clock shows the correct time of day.

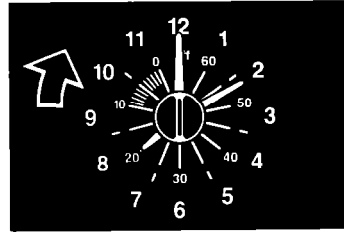

2. Let the Minute Timer Knob pop out. Turn **clockwise** until Minute Timer hand points to OFF. **The clock setting will change if you push in the knob when turning.**

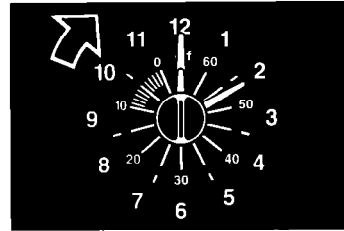

## Using the Minute Timer

The Minute Timer does not start or stop the oven. It works like a kitchen timer. Set it in minutes up to an hour. You will hear a buzzer when the set time is up.

**NOTE: Do not push in the knob** when setting the Minute Timer or when stopping the buzzer. Pushing in and turning the Minute Timer Knob changes the clock setting.

1. **Without pushing it in**, turn the Minute Timer Knob **counterclockwise** until the timer hand passes the setting you want.

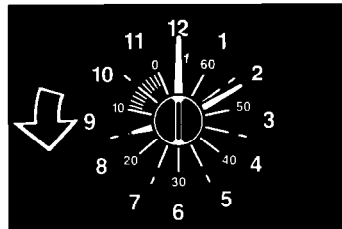

2. **Without pushing it in**, turn the knob back to the setting you want. **When the time is up**, a buzzer will sound. **To stop the buzzer**, turn the Minute Timer hand to OFF.

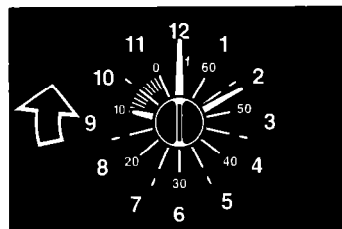

## Baking/roasting

**NOTE:** Do not attempt to light the oven burner during a power failure. See "Important Safety Instructions" on page 5 for more information.

1. **Position** the rack(s) properly **before** turning on the oven. **To change rack position, lift** rack at front, and **pull out**. For further information, **see** "Positioning racks and pans" on page 11.
2. **Set** the Oven Selector to **BAKE**.
3. **Push in and turn** the Oven Temperature Control **counterclockwise** to the baking/roasting temperature you want. The oven burner will automatically light in 50-60 seconds.

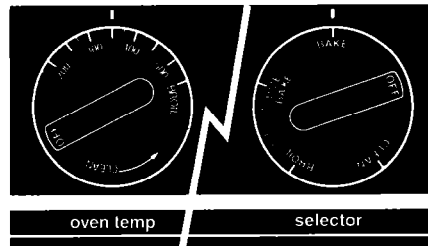

4. **When baking, preheat** the oven for 10 minutes. **Put** food in the oven.

### NOTES:

- **Do not preheat** when roasting or cooking items such as casseroles.
- **Do not place** food directly on the oven bottom.

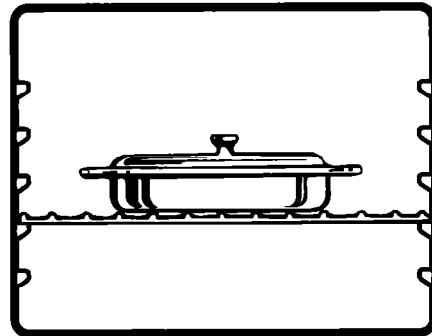

5. **During baking/roasting,** the oven burner will turn on and off to maintain the temperature setting.
6. **When baking/roasting is done,** turn both the Oven Selector and the Oven Temperature Control **clockwise** to **OFF**.

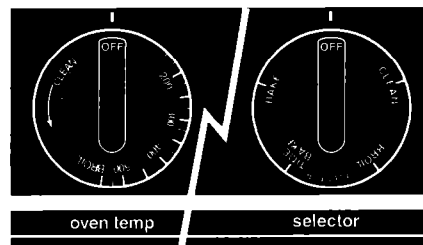

## Adjusting the oven temperature control

Although your new oven is properly adjusted to provide accurate temperatures, it may cook faster or slower than your old oven.

If, after using the oven for a period of time, you are not satisfied with the baking/roasting results, you can change the temperature calibration by following these steps:

1. **Make sure** the Oven Temperature Control Knob is turned to the off position. **Pull** knob straight off and **flip** it over.
2. **Loosen** the locking screws inside the control knob. **Note the position of the notches.**
3. **To lower the temperature, hold** knob handle firmly and **turn skirt clockwise** to move the tooth a notch to the left. Each notch equals about 10°F (5°C).
4. **To raise the temperature, hold** knob handle firmly and **turn skirt counterclockwise** to move the tooth a notch to the right. Each notch equals about 10°F (5°C).
5. **Tighten** the locking screws and **replace** the control knob.

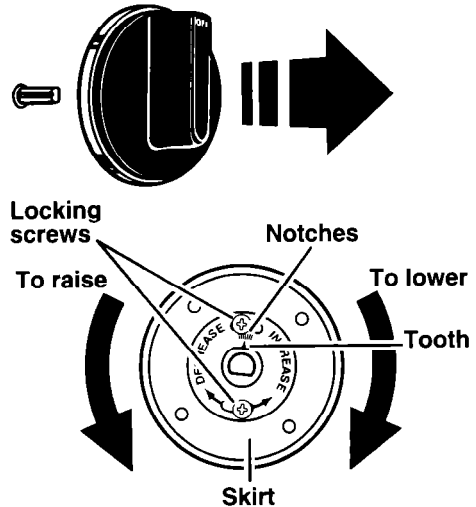

## Broiling

1. **Position** the rack properly **before** turning on the oven. **Position** the oven rack so that the surface of the food is at least 3 inches (7 cm) away from the broil burner. **See** "Broiling rack position chart" on page 17.
2. **Put** the broiler pan and food on the rack.
3. **Completely close** the oven door to ensure proper broiling temperatures.

## USING YOUR RANGE

4. Set the Oven Selector to BROIL. Push in and turn the Oven Temperature Control counterclockwise to BROIL. The broiler will automatically light in 50-60 seconds.

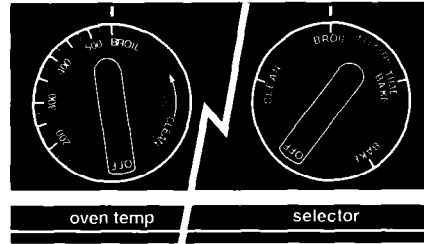

5. When broiling is done, turn both the Oven Selector and the Oven Temperature Control clockwise to OFF.

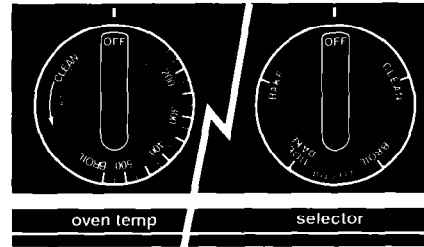

## Broiling tips

- **Use** the broiler pan and grid for broiling. They are designed to drain excess liquid and grease away from the cooking surface to help prevent spatter, smoke, or fire.
- **If you broil** small quantities, you may want to use a small broiler pan. They are available in the housewares section of many department stores.
- **Broiling rack position** determines how the burner cooks your food. The lower the position, the more broiler grid area covered. See "Broiling rack position chart" on page 17 for more information.
- **To sear meat**, place broiler pan at one of the higher rack positions so that meat is very near the flame.
- **Small steaks** may be broiled in the higher rack positions.
- **To cook large steaks** and other thick cuts of meat well done, move them to a lower rack position after searing.

- **After broiling**, remove the broiler pan from the oven when you remove the food. Drippings will bake on the pan if you leave it in the heated oven.

### ⚠ WARNING

#### Fire Hazard

- Place meat the correct distance from the burner. Meat placed too close to the burner could spatter, smoke, burn, or catch fire during broiling.
- To ensure adequate grease drainage, do not use cookie sheets or similar pans for broiling. Also, covering the broiler grid with foil is not recommended. Poor drainage of grease could result in fire.

### Broiling rack position chart

RACK POSITION FROM BOTTOM	FOOD
4	Rare steaks and fish
3	Medium and well-done steaks and hamburgers; well-done foods such as chicken, lobster, ham slices, and pork chops

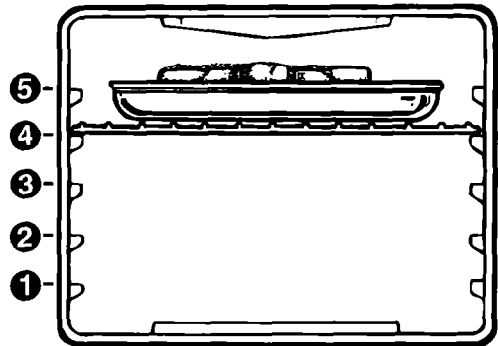

### Energy saving tips

Although the energy used for cooking is usually a very small percentage of the total energy used in the home, cooking energy can be used efficiently. Here are some tips to help you save energy when using your cooking product:

- **Use** pans with flat bottoms, straight sides, and tight-fitting lids.
- **Cook** with a minimum of liquid or fat to help shorten cooking time.
- **Preheat** pans only when recommended and for the shortest time possible.
- **Start** food on higher heat settings, then set surface burner control on low to finish cooking.
- **Use** the more efficient surface burners instead of the oven when possible.
- **Turn on** the surface burner only after placing filled pan on the burner grate.
- **“Oven peeking”** may cause heat loss, longer cooking times, and unsatisfactory baking results. Rely on your timer to keep track of the cooking time.
- **Bake** cakes, pies, or cookies when oven is warm. Best time to bake is right after a meal has been cooked in the oven.
- **Preheat** the oven no longer than necessary.
- **Plan** your meals for the most efficient use of the range. When using the oven to cook one food, try to cook the rest of the meal in it also.
- **Do not preheat** when roasting or cooking items such as casseroles.

## Using the automatic MEALTIMER™ clock

The automatic MEALTIMER clock is designed to turn the oven on and off at times you set, even when you are not around.

Delayed time baking/roasting is ideal for foods which do not require a preheated oven, such as meats and casseroles. **Do not use the delayed time cycle for cakes, cookies, etc. – undercooking will result.**

**Before using the MEALTIMER clock, make sure the clock is set to the correct time of day.** (See “Setting the clock” on page 13.)

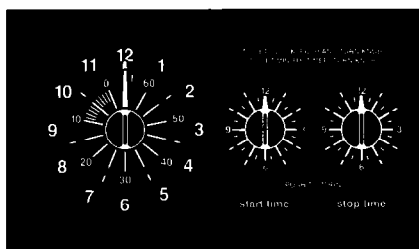

### To delay start and stop automatically:

1. **Position** the oven rack(s) properly and **place** the food in the oven.
2. **Push in and turn** the Start Time Knob **clockwise** to the time you want baking/roasting to start.
3. **Push in and turn** the Stop Time Knob **clockwise** to the time you want the oven to shut off.

**NOTE:** There must be at least a half-hour difference between the start and stop times.

4. **Set** the Oven Selector to TIME BAKE.
5. **Push in and turn** the Oven Temperature Control to the baking/roasting temperature you want. The oven will now start and stop automatically.
6. **After baking/roasting is done or to cancel the setting at any time, turn** both the Oven Selector and Oven Temperature Control to OFF.

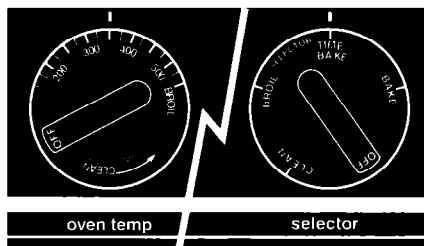
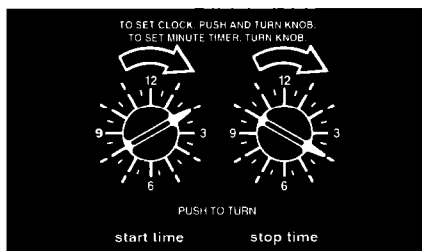

**To start baking/roasting now and stop automatically:**

1. **Position** the oven rack(s) properly and **place** the food in the oven.
2. **Push in and turn** the Stop Time Knob **clockwise** to the time you want the oven to shut off. **Make sure** the Start Time Knob is not pushed in.
3. **Set** the Oven Selector to TIME BAKE.
4. **Push in and turn** the Oven Temperature Control to the baking/roasting temperature you want.
5. **After baking/roasting is done or to cancel the setting at any time, turn** both the Oven Selector and the Oven Temperature Control to OFF.

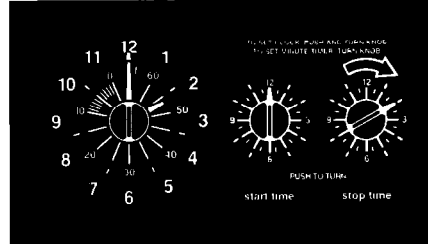

**⚠ WARNING**

**To avoid sickness and food waste when using the MEALTIMER™ clock:**

- Do not let most UNFROZEN food stand for more than two hours before cooking starts.
- Do not allow food to remain in oven for more than two hours after the end of cooking cycle.

**NOTE:** Do not use foods that will spoil while waiting for cooking to start. Such foods are: dishes with milk or eggs, cream soups, and cooked meats or fish. Also, foods containing baking powder or yeast will not rise properly when cooked using delay start.

## The oven vent

Hot air and moisture escape from the oven through a vent located in lower part of backguard. The vent is needed for air circulation. **Do not block the vent.** Poor baking/roasting will result.

**NOTE:** Never store plastics, paper, or other items that could melt or burn near the oven vent, or any of the surface burners.

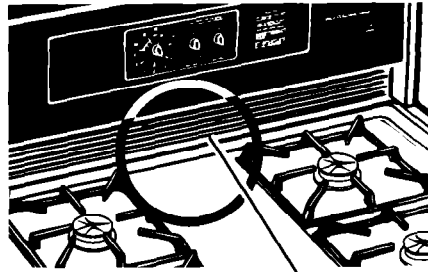

Oven vent

### **⚠ WARNING**

#### **Burn Hazard**

When the oven is ON, pans and pan handles left near the oven vent could become hot enough to burn the user and to melt plastics. Use pot holders to move pans.

## The storage drawer

You can remove the storage drawer to make it easier to clean under the range and to check for installation of the anti-tip bracket(s). **Use care when handling the drawer.**

### Removing the storage drawer:

1. **Empty** drawer before removing. **Pull** drawer straight out to the first stop. **Lift** the front and **pull out** to the second stop.
2. **Let** the drawer rest on the floor. **Place** hands toward the back of the drawer and **lift** it out.

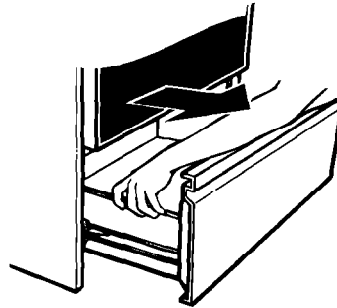

### Replacing the storage drawer:

1. **Place** the set of rollers on the drawer behind the rollers on the range as shown at right.
2. **Line up** the drawer slide rail with the guides on the range and **push** the drawer back into position.

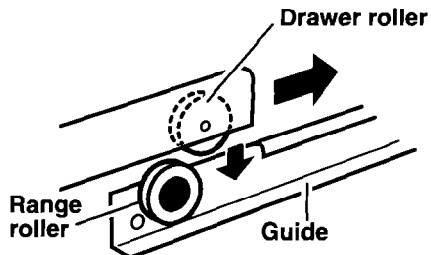

## The anti-tip brackets

The range will not tip during normal use. However, tipping can occur if you apply too much force or weight to the open door without the anti-tip bracket(s) properly secured.

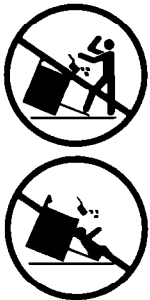
	<p style="text-align: center;"><b>⚠ WARNING</b></p> <p style="text-align: center;"><b>Personal Injury Hazard</b></p> <ul style="list-style-type: none"> <li>• To reduce risk of range tipping over, secure range with properly installed anti-tip bracket(s) supplied with range.</li> <li>• If range is moved for cleaning or service, check that anti-tip bracket(s) is engaged before using range.</li> </ul> <p>Failure to follow the above precautions could result in personal injury.</p>
---	--

### To verify the anti-tip bracket(s) is engaged:

- **Grasp** rear of range and carefully try to tilt forward. If anti-tip bracket(s) is attached to floor with screws and rear leveling leg(s) is positioned under bracket(s), range should not tilt forward.

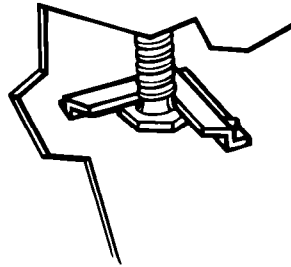

**OR**

- **Remove** the storage drawer. (See page 20.)
- **Make sure** the rear leveling leg(s) is positioned under bracket(s).
- **See** Installation Instructions for further details.

# Using the Self-Cleaning Cycle

The Self-Cleaning cycle saves you from the toil and mess that often come with hand-cleaning the oven interior. Like the other functions of your range, you operate the Self-Cleaning cycle with the easy-to-use controls. Please review the instructions in this section to keep your oven spotless.

## How the cycle works

The Self-Cleaning cycle uses very high heat to burn away soil and grease. During the cycle, the oven gets much hotter than it does for normal baking or broiling. This high heat breaks up the soil or grease and burns it away.

We recommend a 3-hour Self-Cleaning cycle. However, you can adjust the cycle time to the amount of soil in your oven. You can set the cycle anywhere between 2 and 4 hours. (See "Setting the controls" on page 23.)

The graph at the right is representative of a normal, 3-hour Self-Cleaning cycle. Note that the heating stops when the 3-hour setting is up, but it takes longer for the oven to cool enough to unlock.

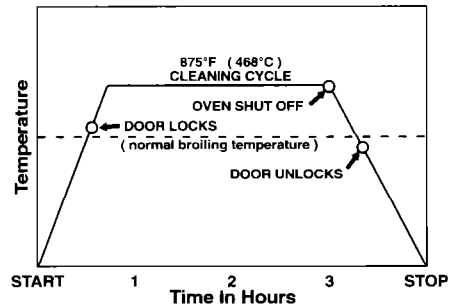

---

## Before you start

Before you start the Self-Cleaning cycle, make sure you:

- **Hand-clean the areas shown.** They do not get hot enough during the cleaning cycle for soil to burn away. Use hot water and detergent or a soapy steel-wool pad for cleaning.

**NOTE:** DO NOT clean, move, or bend the seal. Poor cleaning, baking, and roasting may result.

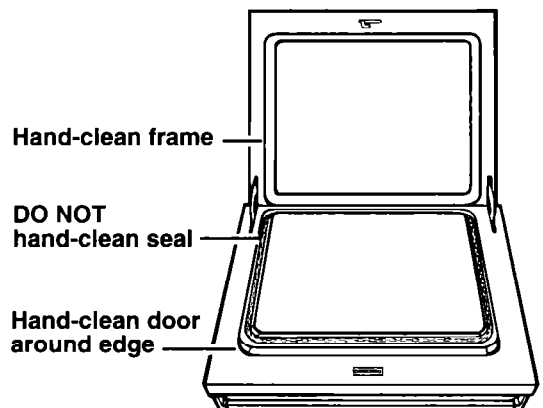

## USING THE SELF-CLEANING CYCLE

- **Remove any pots and pans** being stored in the oven.

**NOTE:** You can clean the broiler pan (without grid) in the oven if you have first removed most of the soil by hand-cleaning or in a dishwasher. If most of the soil is not removed, too much smoking will occur. The chrome broiler grid will discolor if cleaned in the Self-Cleaning cycle.

- **Wipe out any loose soil or grease.** This will help reduce smoke during the Self-Cleaning cycle.
- **Remove the oven racks from the oven if you want them to remain shiny.** You can clean the oven racks in the Self-Cleaning cycle, but they will become harder to slide. (See page 29.) If you clean racks in the Self-Cleaning cycle, place them on the 2nd and 4th rack guides. (Guides are counted from bottom to top.)
- **Heat and odors** are normal during the Self-Cleaning cycle. Keep the kitchen well ventilated by opening a window or by turning on a vent hood or other kitchen vent during the cycle.

### ⚠ WARNING

#### Personal Injury Hazard

- Do not touch the oven during the Self-Cleaning cycle. It could burn you.
- Do not use commercial oven cleaners in your oven. Cleaners could produce hazardous fumes or damage the porcelain finish.

#### NOTES:

- **Do not force** the Lock Lever. You could bend or break it. The lever is designed to stay locked until the oven is cool enough to safely open. Wait until it moves freely.
- **Do not block** the vent during the Self-Cleaning cycle. Air must move freely for best cleaning results.
- **Do not leave** plastic utensils near the vent. They may melt.
- **Do not leave** any foil in oven during the Self-Cleaning cycle. Foil could burn or melt and damage the oven surface.
- **The oven light** will not work during the Self-Cleaning cycle.

## Setting the controls

1. **Set the Oven Selector to CLEAN. Push in and turn the Oven Temperature Control counterclockwise to CLEAN.**

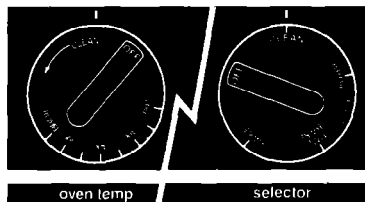

2. **Make sure the clock, and Start and Stop Times all have the correct time of day.**

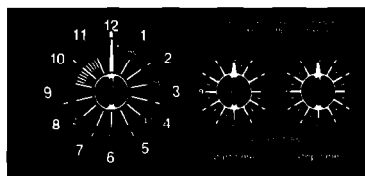

3. **Push in and turn the Stop Time Knob clockwise 2 to 4 hours.**
  - Use 2 hours for light soil.
  - Use 3 hours or more for moderate soil.
  - Use 4 hours for heavy soil.

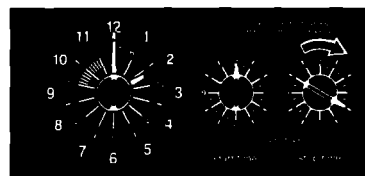

**NOTE:** Make sure the Start Time Knob is not pushed in.

## USING THE SELF-CLEANING CYCLE

4. **Move** the Lock Lever to the right – the Clean position. This will start the Self-Cleaning cycle. If the door is not completely closed or the Lock Lever is not all the way to the right, the cycle will not start.
5. **When the oven temperature goes above normal baking/roasting temperatures**, the door cannot be opened and the Lock Lever must not be moved. When the oven temperature reaches about 700°F, the Clean Indicator Light will go on.
6. **After the Self-Cleaning cycle is completed and the oven reaches normal baking/roasting temperatures**, the Clean Indicator Light will go off. **Move** the Lock Lever back to the left. **DO NOT FORCE IT.** **Wait** until it moves easily. **Turn** the Oven Selector and Oven Temperature Control to OFF.
7. **After the oven is cool, wipe off** any residue or ash with a damp cloth. **If needed, touch up** spots with a soapy steel-wool pad.

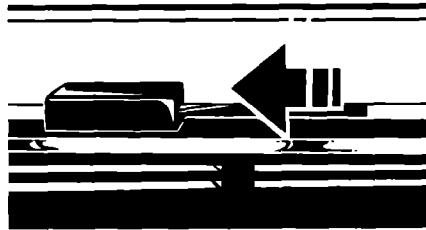
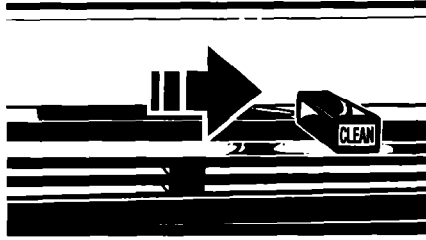

### To stop the Self-Cleaning cycle at any time:

1. **Push in and turn** the Stop Time Knob **clockwise** until it points to the correct time of day.
2. **Turn** the Oven Selector and Oven Temperature Control to OFF. **When the Clean Indicator Light goes off, move** the Lock Lever back to the left. **DO NOT FORCE IT.** **Wait** until it moves easily.

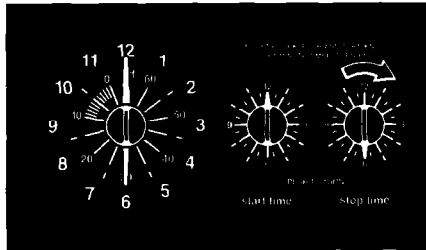

## Special tips

- **Keep** the kitchen well ventilated during the Self-Cleaning cycle to help get rid of heat, odors, and smoke.
- **After the oven is cool**, wipe up any residue or ash with a damp cloth or sponge. If any spots remain, clean with a mild abrasive cleanser or cleaning sponge.
- **Clean** the oven before it gets heavily soiled. Cleaning a very soiled oven takes longer and results in more smoke than usual.
- **If the Self-Cleaning cycle does not get the oven as clean as you expected**, the cycle may not have been set long enough or you may not have prepared the oven properly. Set the Self-Cleaning cycle longer the next time and hand-clean areas noted on page 22.

# Caring for Your Range

Your range is designed for easy care. You can do most cleaning with items found around your home. Cleaning your range whenever spills or soiling occurs will help to keep it looking and operating like new.

## **⚠ WARNING**

### **Explosion Hazard**

- Make sure all controls are OFF and the range is cool before cleaning.
- Do not use oven cleaners, bleach, or rust removers.
- Do not obstruct the flow of combustion and ventilation air.
- Keep appliance area clear and free of combustible materials, gasoline, and other flammable vapors and liquids.

Failure to follow these guidelines could result in burns, electrical shock, fire, or explosion.

## **Surface burner grates**

1. **Make sure** all surface burners are off and the surrounding parts are cool.
2. **Lift off** the surface burner grates.
3. **Wash** the grates with warm, soapy water or in a dishwasher. **Use** a nonabrasive, plastic scrubbing pad for cooked-on foods. **Rinse** and **dry** well.
4. **Replace** burner grates.

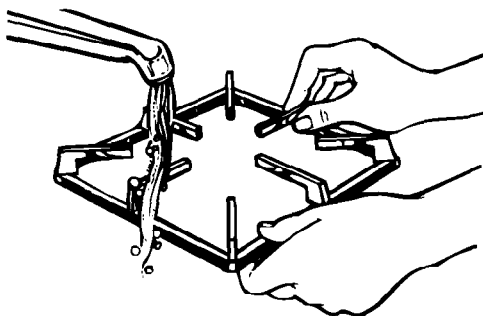

### Surface burners and cooktop

The cooktop and burner box areas are specially designed to make cleaning easier. Because the four burners are sealed, clean-ups are easy and convenient.

**To clean the cooktop, wipe with a damp sponge and dry.**

**NOTE:** Do not remove the cooktop. Doing so could result in product damage.

#### Cleaning the contoured well areas

The contoured well is a recessed area located around each burner.

**If spills occur in contoured well section:**

1. **Blot up** spills with a paper towel.
2. **Wipe** with a clean, damp sponge.
3. **Dry.**

**NOTE:** When cleaning the cooktop area or around the burner base, use care to prevent damage to the ignitor. If a cleaning utensil should catch it, the ignitor could be damaged or broken. If the ignitor is damaged or broken, the surface burner will not light. When cleaning the cooktop, leave the burner cap in place to protect the ignitor from possible damage.

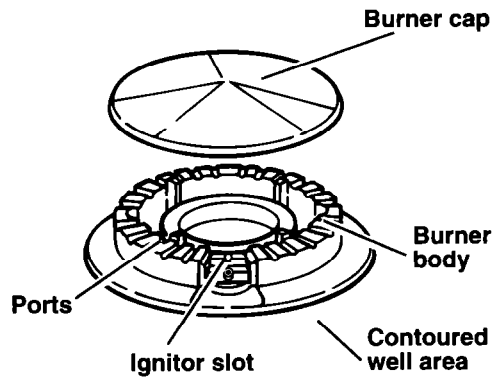

## Cleaning the surface burners

- **The burner caps** should be routinely removed and cleaned. Always clean burner caps after a spillover. Keeping the burner caps clean prevents improper ignition and an uneven flame.
- **For proper flow** of gas and ignition of the burner, **DO NOT ALLOW SPILLS, FOOD, CLEANING AGENTS, OR ANY OTHER MATERIAL TO ENTER THE GAS TUBE OPENING.**
- **Gas must flow freely** through the ignitor slot for the burner to light properly. This area must be free of any soil and be kept protected from boilovers and spillovers. **ALWAYS** keep the burner caps in place whenever a surface burner is in use.

Ignitor slot should remain clean as long as burner cap is seated properly on burner. Occasionally check burner cap to make sure it is level and covers burner completely.

- **Occasionally check** the burner flames for proper size and shape as shown. A good flame is blue in color. If flames lift off ports, are yellow, or are noisy when turned off, you may need to clean the burners.

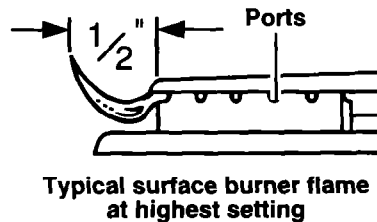
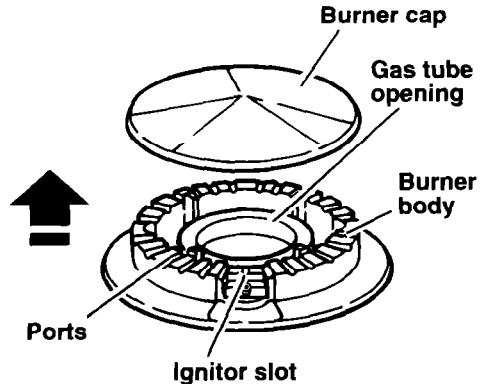

### To clean burners:

1. **Remove** the burner grate.
2. **Pull** the burner cap straight up from the burner base.
3. **Clean** burner cap and burner grate with warm, soapy water and a sponge. You can also clean with a nonabrasive scrubbing pad or cleanser. Do not clean burner cap or burner grate in dishwasher or a self-cleaning oven.
4. **If the gas tube opening** has become soiled or clogged, **use** a cotton swab or a soft cloth to clean the area.
5. **If ports are clogged**, clean with a straight pin. **Do not enlarge or distort port. Do not use a wooden toothpick. If adjustment is needed**, call a qualified technician for service.

## CARING FOR YOUR RANGE

6. **After cleaning** the gas tube opening and ports, **replace** the burner cap and burner grate. **To replace burner cap, make sure** cap is properly aligned and leveled. **Fit** locating pegs into the recess in the underside of the cap. The cap must be correctly seated on the burner body for proper operation of the burner.
7. **Turn on** the burner to determine if it will light. **If the burner does not light after cleaning, contact** an authorized Whirlpool service technician. Do not service the sealed burner yourself.

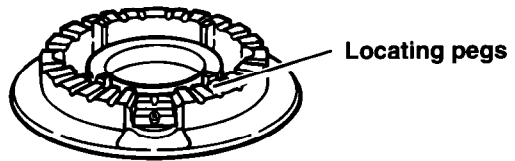

## Cleaning chart

Use the following table to help you clean your range.

PART	WHAT TO USE	HOW TO CLEAN
<b>Control knobs</b>	Sponge and warm, soapy water	<ul style="list-style-type: none"> <li>• Turn knobs to OFF and pull straight away from control panel.</li> <li>• Wash, rinse, and dry thoroughly. Do not soak.</li> <li>• <b>Do not use steel wool or abrasive cleansers. They may damage the finish.</b></li> <li>• Replace knobs. Make sure all knobs point to OFF.</li> </ul>
<b>Control panels</b>	Sponge and warm, soapy water <b>OR</b> Paper towel and spray glass cleaner	<ul style="list-style-type: none"> <li>• Wash, wipe with clean water, and dry thoroughly.</li> <li>• <b>Do not use steel wool or abrasive cleansers. They may damage the finish.</b></li> <li>• Do not spray cleaner directly on panel. Apply cleaner to paper towel.</li> </ul>
<b>Exterior surfaces (other than control panels)</b>	Sponge and warm, soapy water	<ul style="list-style-type: none"> <li>• Wash, wipe with clean water, and dry thoroughly.</li> <li>• Use nonabrasive, plastic scrubbing pad on heavily soiled areas.</li> <li>• <b>Do not use abrasive or harsh cleansers. They may damage the finish.</b></li> </ul> <p><b>NOTE:</b> Do not allow foods containing acids (such as vinegar, tomato, or lemon juice) to remain on surface. Acids may remove the glossy finish. Also wipe up milk or egg spills when cooktop is cool.</p>

PART	WHAT TO USE	HOW TO CLEAN
<b>Surface burners, grates, and caps</b>	Warm, soapy water and a nonabrasive, plastic scrubbing pad <b>OR</b> Dishwasher (for grates)	<ul style="list-style-type: none"> <li>• See pages 25-28 for cleaning instructions.</li> </ul>
<b>Broiler pan and grid</b> (clean after each use)	Steel-wool pad and warm, soapy water	<ul style="list-style-type: none"> <li>• Wash, rinse, and dry thoroughly.</li> <li>• Do not clean in Self-Cleaning oven. (See note on page 23.)</li> </ul>
<b>Oven racks</b>	Steel-wool pad and warm, soapy water <b>OR</b> The Self-Cleaning cycle	<ul style="list-style-type: none"> <li>• Wash, rinse, and dry thoroughly.</li> </ul> <p><b>OR</b></p> <ul style="list-style-type: none"> <li>• Leave in oven during Self-Cleaning cycle.</li> </ul> <p><b>NOTE:</b> Racks will permanently discolor and become harder to slide if left in oven during Self-Cleaning cycle. Apply a small amount of vegetable oil to the side rungs to aid sliding.</p>
<b>Oven door glass</b>	Paper towel and spray glass cleaner <b>OR</b> Warm, soapy water and a nonabrasive, plastic scrubbing pad	<ul style="list-style-type: none"> <li>• Make sure oven is cool.</li> <li>• Follow directions provided with the cleaner.</li> <li>• Wash, wipe with clean water, and dry thoroughly.</li> </ul>
<b>Oven cavity</b>	Self-Cleaning cycle	<ul style="list-style-type: none"> <li>• See "Using the Self-Cleaning Cycle" on pages 22-24.</li> </ul>

## The oven light

The Oven Light will come on when you open the oven door. To turn the light on when the oven door is closed, push the Oven Light Switch on the control panel. Push the switch again to turn off the light.

### **⚠ WARNING**

#### **Electrical Shock Hazard**

- Make sure oven and light bulb are cool and power to the range has been turned off before replacing the light bulb. Failure to do so could result in electrical shock or burns.
- The bulb cover must be in place when using the oven. The cover protects the bulb from breaking, and from high oven temperatures. Because bulb cover is made of glass, be careful not to drop it. Broken glass could cause injury.

### **To replace the oven light:**

1. **Unplug** appliance or **disconnect** at the main power supply.
2. **Remove** the glass bulb cover in the back of the oven by screwing it out counter-clockwise.
3. **Remove** the light bulb from its socket. **Replace** the bulb with a 40-watt appliance bulb.
4. **Replace** the bulb cover by screwing it in clockwise. **Plug in** appliance or **reconnect** at the main power supply.

**NOTE:** The oven light will not work during the Self-Cleaning cycle.

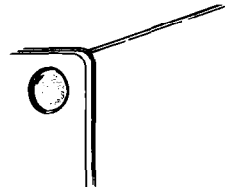
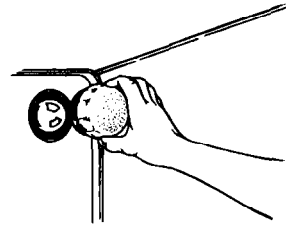

# If You Need Assistance or Service

This section is designed to help you save the cost of a service call. Part 1 of this section outlines possible problems, their causes, and actions you can take to solve each problem. Parts 2 and 3 tell you what to do if you still need assistance or service. When calling our toll-free telephone number for help or calling for service, please provide a detailed description of the problem, your appliance's complete model and serial numbers, and the purchase date. (See page 3.) This information will help us respond properly to your request.

## 1. Before calling for assistance ...

Performance problems often result from little things you can find and fix without tools of any kind. Please check the chart below for problems you can fix. It could save you the cost of a service call.

PROBLEM	POSSIBLE CAUSE	SOLUTION
<b>Nothing will operate</b>	<p>The power cord is not plugged into a live circuit with proper voltage.</p> <p>Range is not properly connected to gas supply.</p> <p>A household fuse has blown or a circuit breaker has tripped.</p> <p>Controls are not set correctly.</p> <p>The flow of combustion and/or ventilation air to the range is blocked.</p>	<p>Plug the power cord into a live circuit with proper voltage. (See Installation Instructions.)</p> <p>Contact an authorized Whirlpool service technician to reconnect range to gas supply. (See Installation Instructions.)</p> <p>Replace household fuse or reset circuit breaker.</p> <p>Reset controls, if needed.</p> <p>Remove blockage to airflow to and around range.</p>
<b>The oven will not operate</b>	<p>The Oven Selector is not turned to BAKE or BROIL.</p> <p>A delayed start time has been set.</p> <p>The Oven Temperature Control is not turned to a temperature setting.</p> <p>The automatic MEALTIMER clock is not set correctly.</p> <p>The Stop or Start Time Knobs for the automatic MEALTIMER clock are not set at the correct time of day.</p>	<p>Turn the Oven Selector to the desired setting.</p> <p>Wait for the start time to be reached.</p> <p>Push in and turn the Oven Temperature Control to a temperature setting.</p> <p>Set the MEALTIMER clock correctly. (See "Using the automatic MEALTIMER™ clock" on page 18.)</p> <p>If a delay start or stop is not desired, the Stop and Start Time Knobs must be turned to the correct time of day. Turn knobs till they pop out.</p>

continued on next page

## IF YOU NEED ASSISTANCE OR SERVICE

PROBLEM	POSSIBLE CAUSE	SOLUTION
<b>Burner fails to light</b>	<p>The power cord is not plugged into a live circuit with proper voltage.</p> <p>A household fuse has blown or a circuit breaker has tripped.</p> <p>Burner ports are clogged.</p>	<p>Plug the power cord into a live circuit with proper voltage. (See Installation Instructions.)</p> <p>Replace household fuse or reset circuit breaker. In case of prolonged power failure, manually light burners (see page 10).</p> <p>Clean with a straight pin (see page 27).</p>
<b>Burner flames are uneven</b>	Burner ports are clogged.	Clean with a straight pin (see page 27). If this fails, call an authorized Whirlpool service technician for service.
<b>Burner flames lift off ports, are yellow, or are noisy when turned off</b>	Air/gas mixture is incorrect.	Contact an authorized Whirlpool service technician to check air/gas mixture.
<b>Burner makes popping noise when on</b>	Burner is wet from washing.	Let dry.
<b>Control knob(s) will not turn</b>	You are not pushing in before turning.	Push control knob(s) in before turning to a setting.
<b>Self-Cleaning cycle will not operate</b>	<p>The Oven Selector and Oven Temperature Control are not set to CLEAN.</p> <p>The range clock does not show the correct time of day.</p> <p>The Lock Lever is not in the CLEAN position – all the way to the right.</p> <p>The Start Time Dial does not show the correct time of day or the knob is not all the way out.</p> <p>The Stop Time Dial is not set ahead to the time you want the Self-Cleaning cycle to stop.</p>	<p>Set both the Oven Selector and Oven Temperature Control to CLEAN.</p> <p>Reset clock to show the correct time of day. (See page 13.)</p> <p>Move Lock Lever all the way to the right.</p> <p>Reset the Start Time Knob to show the correct time of day. Pull knob out all the way.</p> <p>See Step 3 in “Setting the controls” on page 23 for proper setting instructions.</p>

PROBLEM	POSSIBLE CAUSE	SOLUTION
<p><b>Cooking results are not what you expected</b></p>	<p>The range is not level.</p> <p>The oven temperature seems too low or too high.</p> <p>The oven was not preheated as the recipe calls for.</p> <p>The recipe has never been tested or is not from a reliable source.</p> <p>The pans are not the type or size recommended in the recipe.</p> <p>There is not proper air circulation around pan when baking.</p> <p>Flame size does not fit the cooking utensil being used.</p> <p>When broiling, you have not completely closed the oven door.</p>	<p>Level range. (See Installation Instructions.)</p> <p>Adjust the oven temperature control. (See "Adjusting the oven temperature control" on page 15.)</p> <p>Preheat oven if called for in recipe.</p> <p>Use only tested recipes from a reliable source.</p> <p>Refer to a reliable cookbook for recommended pan type and size.</p> <p>Allow 1½ to 2 inches (4-5 cm) on all sides of the pans for air circulation. There must be a minimum space of 1 inch (2.5 cm).</p> <p>Adjust flame size to fit cooking utensil.</p> <p>Completely close oven door.</p>

## **2. If you need assistance ...**

Call Whirlpool Consumer Assistance Center telephone number. Dial toll-free from anywhere in the U.S.A.:

**1-800-253-1301**

and talk with one of our trained consultants. The consultant can instruct you in how to obtain satisfactory operation from your appliance or, if service is necessary, recommend a qualified service company in your area.

If you prefer, write to:

Mr. William Clark  
Consumer Assistance Representative  
Whirlpool Corporation  
2000 North M-63  
Benton Harbor, MI 49022-2692

Please include a daytime phone number in your correspondence.

## **3. If you need service ...**



Whirlpool has a nationwide network of authorized Whirlpool service companies.

Whirlpool service

technicians are trained to fulfill the product warranty and provide after-warranty service, anywhere in the United States. To locate the authorized Whirlpool service company in your area, call our Consumer Assistance Center telephone number (see Step 2) or look in your telephone directory Yellow Pages under:

**• APPLIANCE-HOUSEHOLD-MAJOR, SERVICE & REPAIR**

- See: Whirlpool Appliances or Authorized Whirlpool Service (Example: XYZ Service Co.)

**• WASHING MACHINES & DRYERS, SERVICE & REPAIR**

- See: Whirlpool Appliances or Authorized Whirlpool Service (Example: XYZ Service Co.)

## **4. If you need FSP® replacement parts ...**

FSP is a registered trademark of Whirlpool Corporation for quality parts. Look for this symbol of quality whenever you need a replacement part for your Whirlpool® appliance. FSP replacement parts will fit right and work right, because they are made to the same exacting specifications used to build every new Whirlpool appliance.

To locate FSP replacement parts in your area, refer to Step 3 or call the Whirlpool Consumer Assistance Center number in Step 2.

## **5. If you are not satisfied with how the problem was solved ...**

- Contact the Major Appliance Consumer Action Panel (MACAP). MACAP is a group of independent consumer experts that voices consumer views at the highest levels of the major appliance industry.
- Contact MACAP only when the dealer, authorized servicer, and Whirlpool have failed to resolve your problem.  
Major Appliance Consumer Action Panel  
20 North Wacker Drive  
Chicago, IL 60606
- MACAP will in turn inform us of your action.

# WHIRLPOOL® Gas Range Warranty

LENGTH OF WARRANTY	WHIRLPOOL WILL PAY FOR
<b>FULL ONE-YEAR WARRANTY</b> From Date of Purchase	FSP® replacement parts and repair labor to correct defects in materials or workmanship. Service must be provided by an authorized Whirlpool service company.
<b>WHIRLPOOL WILL NOT PAY FOR</b>	
<p><b>A.</b> Service calls to:</p> <ol style="list-style-type: none"> <li>1. Correct the installation of your range.</li> <li>2. Instruct you how to use your range.</li> <li>3. Replace house fuses or correct house wiring or plumbing.</li> <li>4. Replace owner accessible light bulbs.</li> </ol> <p><b>B.</b> Repairs when your range is used in other than normal, single-family household use.</p> <p><b>C.</b> Pickup and delivery. Your range is designed to be repaired in the home.</p> <p><b>D.</b> Damage to your range caused by accident, misuse, fire, flood, acts of God, or use of products not approved by Whirlpool.</p> <p><b>E.</b> Repairs to parts or systems caused by unauthorized modifications made to the appliance.</p>	

5/93

WHIRLPOOL CORPORATION SHALL NOT BE LIABLE FOR INCIDENTAL OR CONSEQUENTIAL DAMAGES. Some states do not allow the exclusion or limitation of incidental or consequential damages, so this limitation or exclusion may not apply to you. This warranty gives you specific legal rights, and you may also have other rights which vary from state to state.

Outside the United States, a different warranty may apply. For details, please contact your authorized Whirlpool distributor or military exchange.

If you need service, first see the "If You Need Assistance or Service" section of this book. After checking "If You Need Assistance or Service," additional help can be found by calling our Consumer Assistance Center telephone number, **1-800-253-1301**, from anywhere in the U.S.A.



Printed on recycled paper—  
10% post-consumer waste  
50% recovered materials

**PART NO. 36-314446-03-0/4363408**

© 1994 Whirlpool Corporation

® Registered Trademark/TM Trademark of Whirlpool, U.S.A.

Printed in U.S.A.